



QX Winkelschrauber Serie

Produktzeichnungen / Maße

QX-Artikelnummer Aufschlüsselung

Modell ID: **QX X D 5 A T 080 P Q 08 – E10**

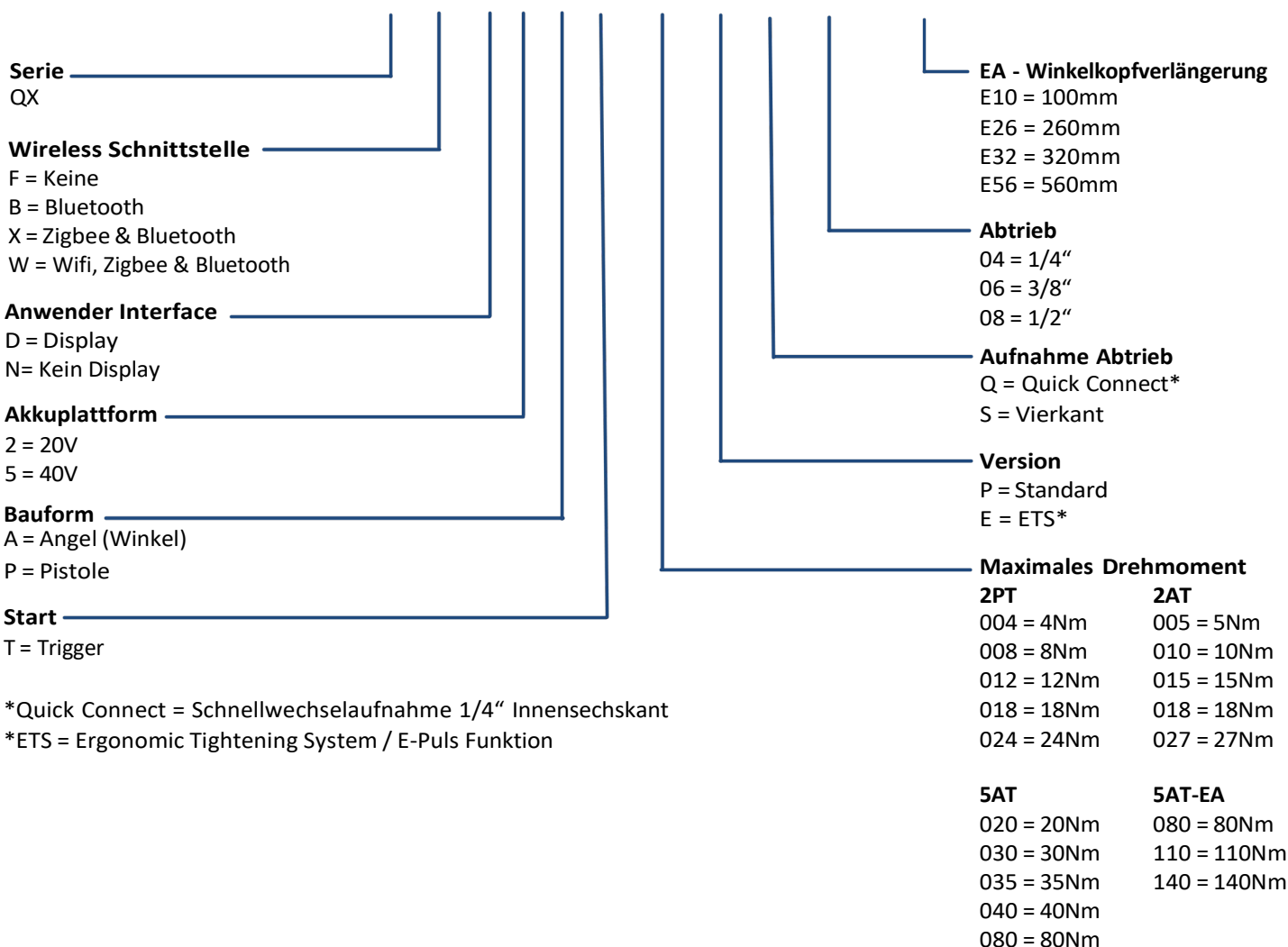

QX Winkelschrauber Serie

Produktzeichnungen / Maße

QX()5AT020PS06 / QX()5AT030PS06 / QX()5AT035PS06

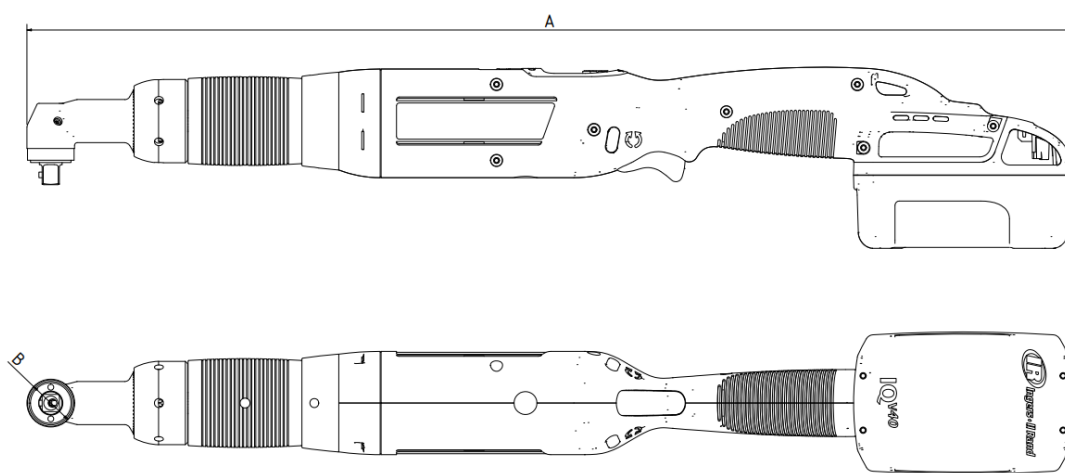

QX()D5AT030PS08 / QX()D5AT035PS08

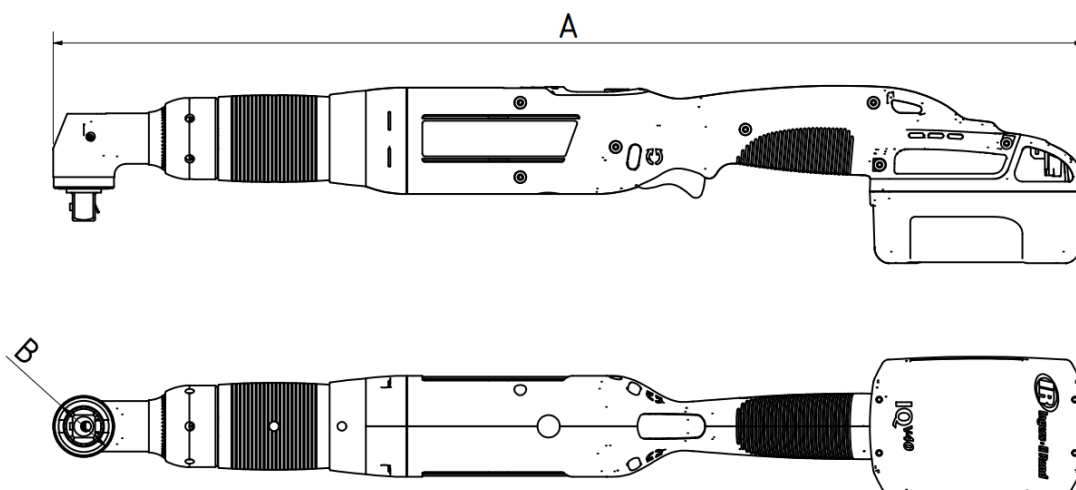

QX Winkelschrauber Serie

Produktzeichnungen / Maße

QX()D5AT040PS08 / QX()D5AT080PS08

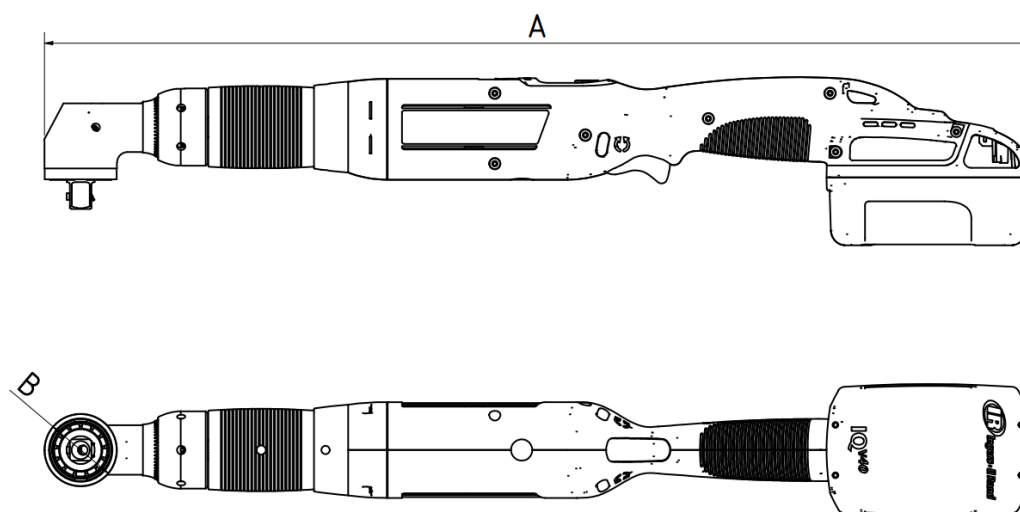

QX()D5AT080PS08-E10

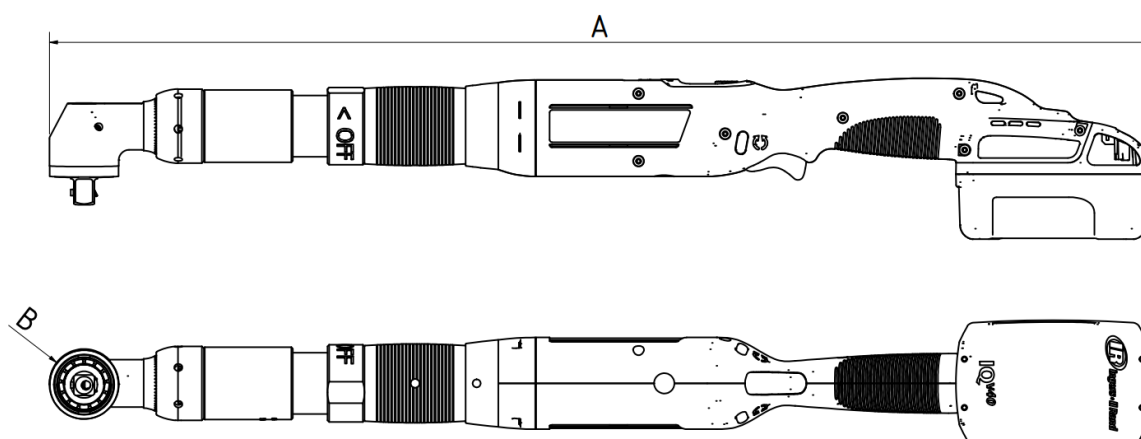

QX Winkelschrauber Serie

Produktzeichnungen / Maße

QX(D5AT110PS08-E06

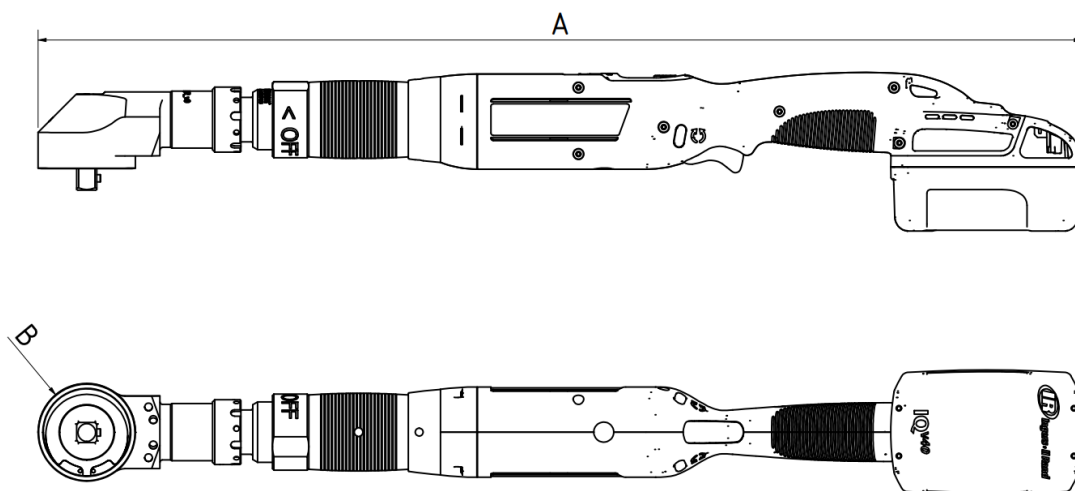

QX(D5AT110PS08-E26

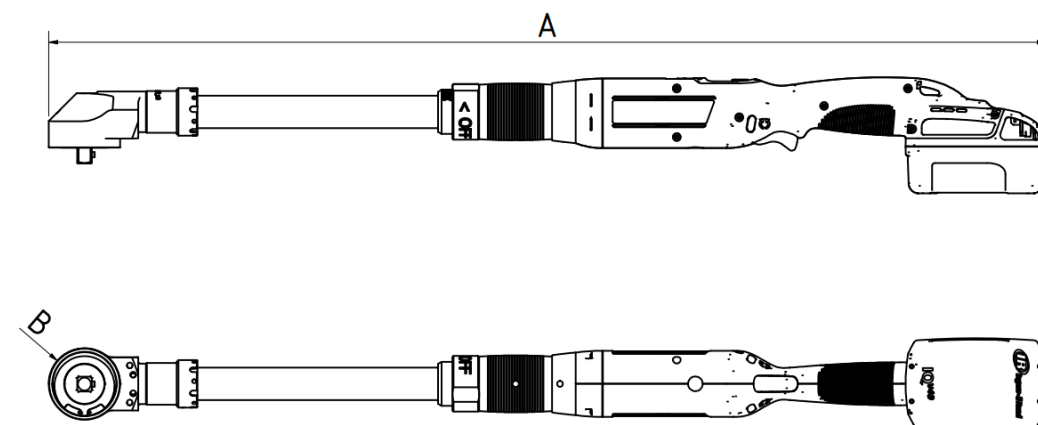

QX Winkelschrauber Serie

Produktzeichnungen / Maße

QX()D5AT110PS08-E32

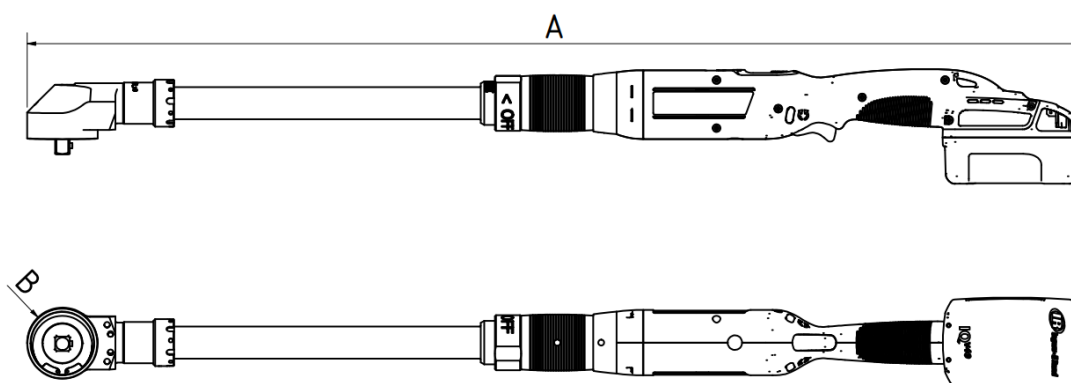

QX()D5AT110PS08-E56

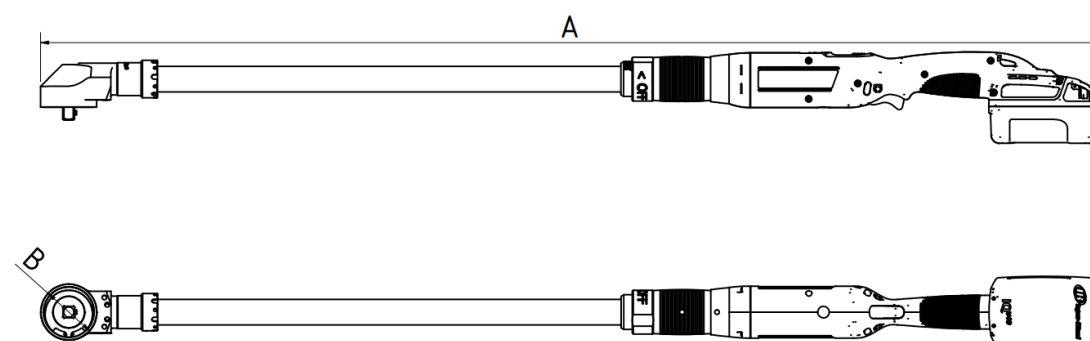

QX Winkelschrauber Serie

Produktzeichnungen / Maße

QX()D5AT140PS08-E06

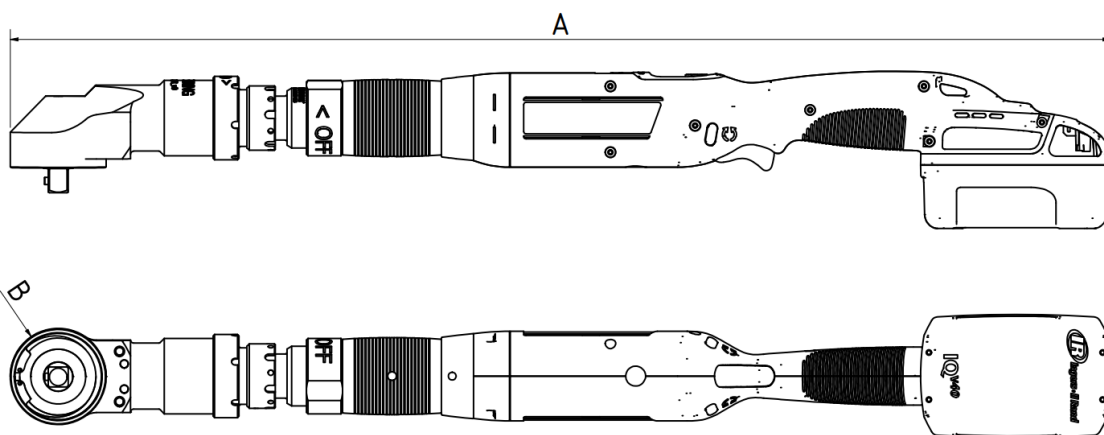

QX()D5AT140PS08-E26

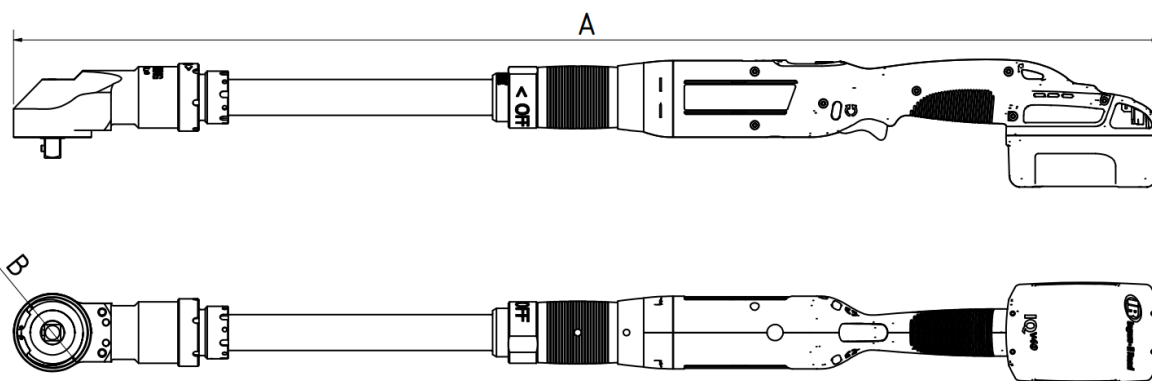

QX Winkelschrauber Serie

Produktzeichnungen / Maße

QX()D5AT140PS08-E32

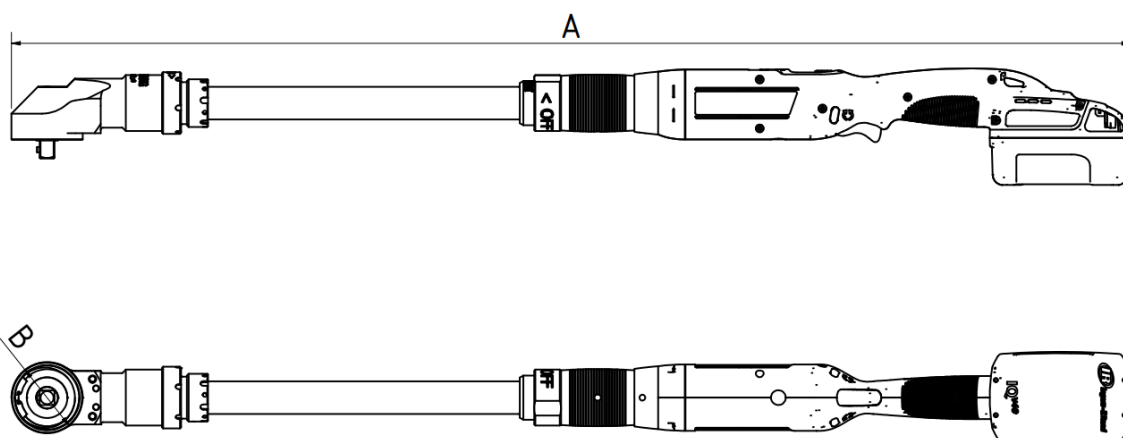

QX()D5AT140PS08-E56

