

TUBE END MILLING UNIT

Made in Germany

- High cutting capacity
- Quick and secure clamping
- Rugged and compact type of construction
- Easy handling



MF3-25

Field of application

The unit serves to machine and prepare welding edges on tubes, branches and headers. On steambloc boilers it is used for machining tube walls and cutting out welds. Having a low weight the unit is of very rugged design. Operated by one man only, it is well suited for use in the workshop and on site. Due to its extremely compact type of construction it can be readily used in confined space. Its high working speed and quick readiness allow economical manufacturing.

TECHNICAL DATA

Working range:

Tube outside diameter:	min. 20 mm max. 63,5 mm
Inside tube diameter:	min. 12,5 mm
Tube wall thickness:	max. 15 mm
Form of weld:	I, V or special form
Minimum width of membrane wall ports:	56 mm

Feed:	manual
Spindle stroke:	25 mm

Weight:

with pneumatic drive:	approx. 8,8 kg
with electric drive:	approx. 10,3 kg

Pneumatic geared motor:

Power:	740 W at 6 bar 400 W at 4 bar
Operating pressure:	6 - 7 bar
Air consumption:	0,96 m ³ /min
Compressed air connection:	R 1/4"

Electric geared motor:

Power consumption/Connection voltage:
abt. 1200W with 230 V

~ (singlephase-alternating current)
Protective class
II – all-insulatet

Besides the conventional design in which the motor and the milling spindle are arranged in line, the unit is on request provided with an angle drive. Therefore, it can be used in special situations if for limited space applications if a short overall length is required.

MF3-25

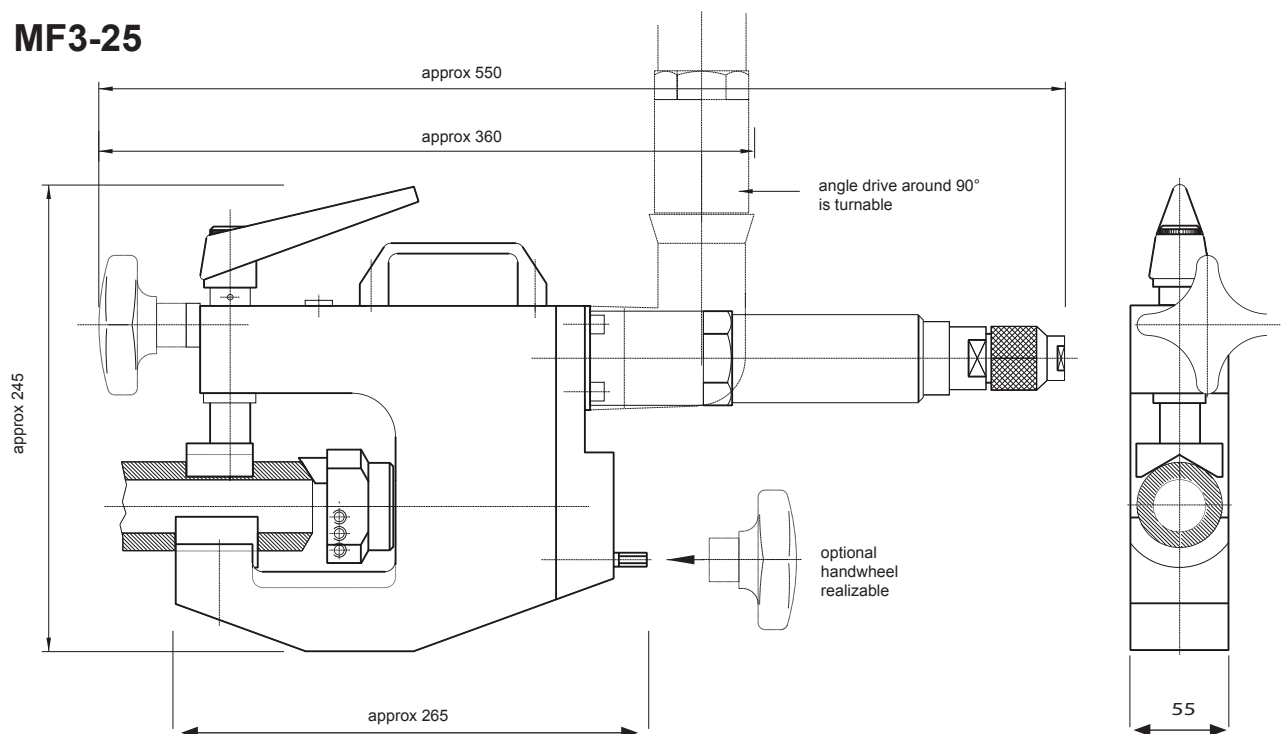

BLADE & TOOL TIP HOLDER

with adjustable holder for tube end milling type **MF3-25**



091501105
HSS
cutting tool tip 0°



091501028
HSS
cutting tool tip 30°



091501106
HSS
cutting tool tip 0° TIN



091501108
HSS
cutting tool tip 30° TIN

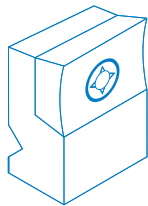

091502138
cutting tool tip holder 0°

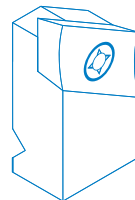

091502136
cutting tool tip holder 30°

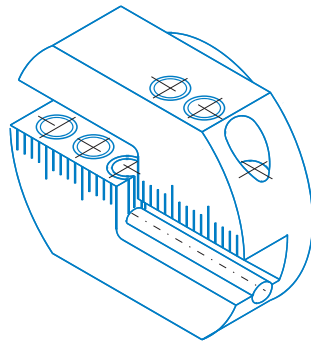

adjustable blade holder
091502121
Standard blade holder



091502141
HSS blade 0°



091502140
HSS blade 30°



091502162
10° - internal



091502163
8° - internal



091502135
10° - internal



091502160
DIN 2559-4



091502148
DIN 2559-3



091502154
DBS 34-R3



091502159
DBS 34-R5

Various special blades on request!

SPECIAL TOOL TIP HOLDERS

for tube end milling unit type **MF3-25**



091501105
HSS
cutting tool tip 0°



091501028
HSS
cutting tool tip 30°



091501106
HSS
cutting tool tip 0° (TIN)



091501108
HSS
cutting tool tip 30° (TIN)

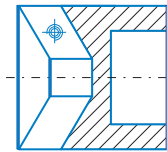

091501029
cutting tool tip holder 30°
(Ø 20 - Ø 44,5)

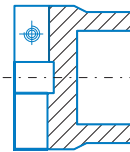

091501031
cutting tool tip holder 0°
(Ø 20 - Ø 44,5)

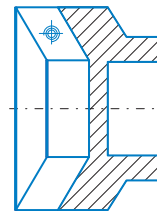

091501030
cutting tool tip holder 30°
(Ø 35 - Ø 63,5)

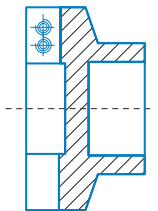

091501032
cutting tool tip holder 0°
(Ø 30 - Ø 63,5)

With small cutting tool tips



091500591
HSS
tool tip holder 30° (small)
(TIN)



091500592
HSS
tool tip holder 30° (small)
(TIN)

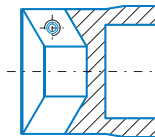

091500586
cutting tool tip holder 30°
(Ø 16 - Ø 38)

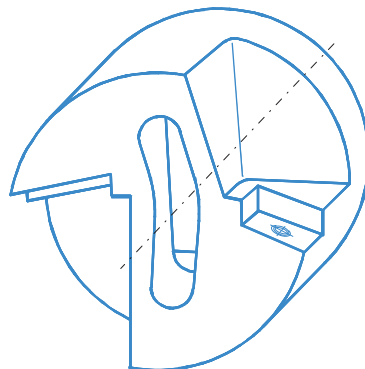

MEMBRANE WALL MACHINING

with crown milling cutters

Made in Germany

For tube milling unit MF3-25 and MF4

- High cutting capacity
- Tool tips can be used twiced
- Easy to change on site
- Modular designed for different tube dimensions



After the formerly offered fullsteel crown milling cutters we can now offer after two years of test experience on site a new type of crown milling cutters. The tool is equipped with tool tips to cut of the bars between the tubes of the panel wall and in the same step to bevel the tube end.

It is mainly consisting of:

- 1 base holder for each machine type
- 1 tool tip milling cutter for each diameter
- 2 tool tip holder 30° are for all diameters identical. Tool tips and screws are identical as well for all applications.

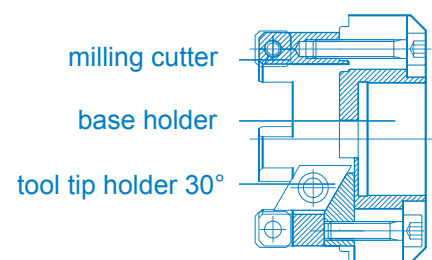

TOOL TIP CROWN MILLING CUTTER

Survey MF3-25 / MF4

Tube - Ø (mm)	All necessary parts for one complete unit					Spare parts			
	1	2	3	4	5	6	7	8	9
	TT crown milling cutter with Knox screws M4 and 4 screws M5x25 (Art.-No.)	TT 0° Art.-No.: 91502494 Number (Pieces)	Basic holder (compl. thread-pin M8 x 10) (Art.-No.)	TT-tool tip holder 30° 2 pieces per crown milling cutters (Art.-No.)	TT 30° for tool tip holder 1 pcs. per TT-holder (Art.-No.)	Knox screws M4 (TT) 1 pcs. per TT (Art.-No.)	Holding-down bolts		
						Screw M5 x 20 4 pcs. (Art.-No.)	Screw M5 x 20 1 pcs. per TT-holder (Art.-Nr.)	Thread-pin M8 x 10 1 pcs. per basic holder (Art.-No.)	
MF3-25									
30,0	091502588	6							
31,8	091502484	6	091502458						
33,7	091502467	6	(Gr. 1)						
35,0	091502485	6	oder						
38,0	091502457	6	091502460	091502483					
42,4	091502486	6	(Gr. 2)	compl. with					
44,5	091502487	6		1 Knox screw	091502495	091502468	000488737	000983010	091500642
48,3	091502488	8		M4 and					
				M5 x 20					
51,0	091502489	8							
57,0	091502459	8	091502460						
60,3	091502490	8	(Gr. 2)						
63,5	091502491	10							
MF4									
44,5	091502487	6							
48,3	091502488	8		091502483					
51,0	091502489	8		compl. with					
57,0	091502459	8	091502479	1 Knox screw	091502495	091502468	000488737	000983010	091500642
60,3	091502490	8		M4 and					
63,5	091502491	10		1 screw					
70,0	091502492	10		M5 x 20					
76,1	091502493	10							