

Pneutorque® PTM-52 Series Stall Models

The PTM-52 is engineered to be one of the lightest and fastest tools of its type on the market. The exceptionally compact 52mm diameter gearbox means that the tool is well balanced, light weight and provides excellent access to bolts.

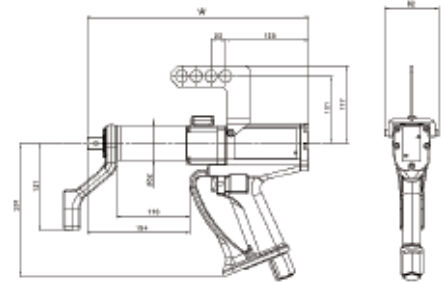

PTM-52-800-B

- Fast – 800 N.m version has a free speed of 175 rpm for rapid bolt run-down.
- Light weight – single direction stall tool weighs just 3.8 kg.
- Quiet – less than 85 dB(A) when under load.
- Non impacting – low vibration levels make these tools comfortable and safe to use.
- Square drive is quickly and easily replaceable.
- On Bi-directional tools, the direction control knob is locked while the tool is running to prevent accidental damage to the gearbox.
- 'Soft Start' trigger control aids socket location and allows gradual and safe reaction location.
- For safety, gearbox can rotate independently from the handle so that reaction forces are not transmitted back to the operator.
- 1" square drive available, Part No. 18545.

500 and 800 N.m Tools - Stall

| Model | Direction of Operation | Square Drive | Part No. | Range | | Free Speed † | Length 'A' | Tool Weight | Reaction Weight |
|--------------|------------------------|--------------|-----------|---------|---------|--------------|------------|-------------|-----------------|
| | | in | | N.m | lbf.ft | | | | |
| PTM-52-500-F | Forward only | ¾ | 18100.F06 | 100-500 | 74-370 | 245 | 284 | 3.8 | 0.85 |
| PTM-52-500-B | Bi-directional | ¾ | 18100.B06 | 100-500 | 74-370 | 245 | 333 | 4.1 | 0.85 |
| PTM-52-800-F | Forward only | ¾ | 18101.F06 | 160-800 | 118-590 | 175 | 284 | 3.8 | 0.85 |
| PTM-52-800-B | Bi-directional | ¾ | 18101.B06 | 160-800 | 118-590 | 175 | 333 | 4.1 | 0.85 |

† Speed at maximum air pressure.

Pneutorque® PTM-52 Series Internal Control and External Control Models

The integration of electronic torque measurement and control into the PTM-52 Series is achieved with the minimum impact on overall tool size and weight. The actual applied torque is accurately measured at the output of the tool meaning that a repeatability of +/-2% can be guaranteed.

Shut-Off, Internal Control – these tools include a torque transducer, easy to read LED display, control panel and a solenoid valve to shut off the air supply once the desired torque has been reached. The tolerance band within which the bolt must be tightened can be set on the tool handle control panel. When the tool is operated, the actual applied torque is displayed along with one of three coloured LEDs to indicate a low, within tolerance or high result. The tool can be operated in either N.m or lbf.ft.

Shut-Off, External Control – this version of the PTM-52 incorporates a transducer, solenoid valve and three coloured LEDs for the indication of low, within tolerance or high results. However, all control functions and torque display are housed in an external controller unit (purchased separately). External controllers can give a much greater range of functionality than is possible on the 'Internal Control' version of the tool.



PTM-52-800-B-IC



Tool controller in wall box for external control versions.
Part No. 60244 without printer or 60254 with printer.
Cable for use with PTM tools, Part No. 61127.600.

500 and 800 N.m Tools - Shut-Off, Internal

| Model | Direction of Operation | Square Drive | Part No. | Range | | Free Speed † | Length 'A' | Tool Weight | Reaction Weight |
|-----------------|------------------------|--------------|-----------|---------|---------|--------------|------------|-------------|-----------------|
| | | in | | N.m | lbf.ft | rpm | mm | kg | kg |
| PTM-52-500-B-IC | Bi-directional | 3/4 | 18110.B06 | 100-500 | 74-370 | 245 | 397 | 4.9 | 0.85 |
| PTM-52-800-B-IC | Bi-directional | 3/4 | 18111.B06 | 160-800 | 118-590 | 175 | 397 | 4.9 | 0.85 |

500 and 800 N.m Tools - Shut-Off, External

| Model | Direction of Operation | Square Drive | Part No. | Range | | Free Speed † | Length 'A' | Tool Weight | Reaction Weight |
|-----------------|------------------------|--------------|-----------|---------|---------|--------------|------------|-------------|-----------------|
| | | in | | N.m | lbf.ft | rpm | mm | kg | kg |
| PTM-52-500-B-EC | Bi-directional | 3/4 | 18120.B06 | 100-500 | 74-370 | 245 | 397 | 4.9 | 0.85 |
| PTM-52-800-B-EC | Bi-directional | 3/4 | 18121.B06 | 160-800 | 118-590 | 175 | 397 | 4.9 | 0.85 |

† Speed at maximum air pressure.

Pneutorque® PTM-72 Series Stall Models

PTM-72 tools use the same 'twin motor' handle as the PTM-52 but fitted with a durable 72mm gearbox to allow higher torque outputs. The 'twin motor' concept gives the benefit of high run-down speeds while adding very little to the size and weight of the tool.



PTM-72-1000-B

- Fast - 1000 N.m version has a free speed of 140 rpm for rapid bolt run-down.
- Light weight - single direction 2000 N.m stall tool weighs just 6.2 kg.
- Quiet - less than 85 db(A) when under load.
- Non impacting - low vibration levels make these tools comfortable and safe to use.
- Square drive is quickly and easily replaceable.
- On Bi-directional tools, the direction control knob is locked while the tool is running to prevent accidental damage to the gearbox.
- 'Soft Start' trigger control aids socket location and allows gradual and safe reaction location.
- For safety, gearbox can rotate independently from the handle so that reaction forces are not transmitted back to the operator.
- 1" square drive available for the 1000 N.m version, Part No. 18492.

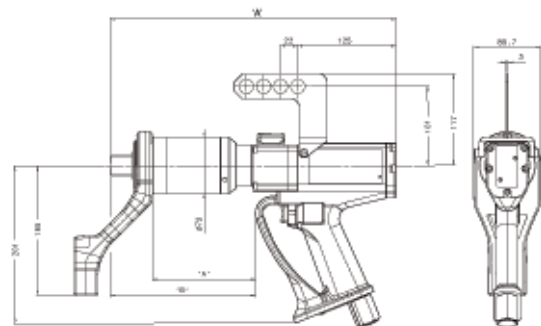

1000, 1350 and 2000 N.m Tools - Stall

| Model | Direction of Operation | Square Drive | Part No. | Range | | Free Speed † | Length 'A' | Tool Weight | Reaction Weight |
|---------------|------------------------|--------------|-----------|----------|----------|--------------|------------|-------------|-----------------|
| | | | | N.m | lbf.ft | | | | |
| PTM-72-1000-F | Forward only | 3/4 | 18102.F06 | 200-1000 | 147-738 | 140 | 316 | 5.8 | 0.7 |
| PTM-72-1000-B | Bi-directional | 3/4 | 18102.B06 | 200-1000 | 147-738 | 140 | 365 | 6.1 | 0.7 |
| PTM-72-1350-F | Forward only | 1 | 18103.F08 | 270-1350 | 200-1000 | 105 | 316 | 5.8 | 0.7 |
| PTM-72-1350-B | Bi-directional | 1 | 18103.B08 | 270-1350 | 200-1000 | 105 | 365 | 6.1 | 0.7 |
| PTM-72-2000-F | Forward only | 1 | 18104.F08 | 400-2000 | 295-1475 | 70 | 349 | 6.2 | 0.7 |
| PTM-72-2000-B | Bi-directional | 1 | 18104.B08 | 400-2000 | 295-1475 | 70 | 398 | 6.5 | 0.7 |

† Speed at maximum air pressure.

Pneutorque® PTM-72 Series Internal Control and External Control Models

The integration of electronic torque measurement and control into the PTM-72 Series is achieved with the minimum impact on overall tool size and weight. The actual applied torque is accurately measured at the output of the tool meaning that a repeatability of +/-2% can be guaranteed.

Shut-Off, Internal Control - these tools include a torque transducer, easy to read LED display, control panel and a solenoid valve to shut off the air supply once the desired torque has been reached. The tolerance band within which the bolt must be tightened can be set on the tool handle control panel. When the tool is operated, the actual applied torque is displayed along with one of three coloured LEDs to indicate a low, within tolerance or high result. The tool can be operated in either N.m or lbf.ft.

Shut-Off, External Control - this version of the PTM-72 incorporates a transducer, solenoid valve and three coloured LEDs for the indication of low, within tolerance or high results. However, all control functions and torque display are housed in an external controller unit (purchased separately), see page 43 for details. External controllers can give a much greater range of functionality than is possible on the 'Internal Control' version of the tool.



PTM-72-2000-B-EC

1000, 1350 and 2000 N.m Tools - Shut-Off, Internal

| Model | Direction of Operation | Square Drive in | Part No. | Range | | Free Speed † rpm | Length 'A' mm | Tool Weight kg | Reaction Weight kg |
|------------------|------------------------|--------------------|-----------|----------|----------|---------------------|------------------|-------------------|-----------------------|
| | | | | N.m | lbf.ft | | | | |
| PTM-72-1000-B-IC | Bi-directional | ¾ | 18112.B06 | 200-1000 | 147-738 | 140 | 422 | 7.4 | 0.7 |
| PTM-72-1350-B-IC | Bi-directional | 1 | 18113.B08 | 270-1350 | 200-1000 | 105 | 422 | 7.4 | 0.7 |
| PTM-72-2000-B-IC | Bi-directional | 1 | 18114.B08 | 400-2000 | 295-1475 | 70 | 453 | 7.8 | 0.7 |

1000, 1350 and 2000 N.m Tools - Shut-Off, External

| Model | Direction of Operation | Square Drive in | Part No. | Range | | Free Speed † rpm | Length 'A' mm | Tool Weight kg | Reaction Weight kg |
|------------------|------------------------|--------------------|-----------|----------|----------|---------------------|------------------|-------------------|-----------------------|
| | | | | N.m | lbf.ft | | | | |
| PTM-72-1000-B-EC | Bi-directional | ¾ | 18122.B06 | 200-1000 | 147-738 | 140 | 422 | 7.4 | 0.7 |
| PTM-72-1350-B-EC | Bi-directional | 1 | 18123.B08 | 270-1350 | 200-1000 | 105 | 422 | 7.4 | 0.7 |
| PTM-72-2000-B-EC | Bi-directional | 1 | 18124.B08 | 400-2000 | 295-1475 | 70 | 453 | 7.8 | 0.7 |

† Speed at maximum air pressure.



Pneutorque® PTM-92 and PTM-119 Series Stall Models

The latest extension to the PTM tool range brings the speed advantage of the twin motor handle to higher capacity Pneutorque models.

Coupled with new gearbox designs, these new models deliver an ideal balance between robustness, speed and weight.



PTM-92-3500

- Fast - 2700 N.m version has a free speed of 57 rpm for rapid bolt run-down time.
- Light weight - PTM-92-2700 weighs just 8.5kg. All models are fitted as standard with a light but robust aluminium reaction plate.
- Other reaction styles are available for maximum versatility.
- Quiet - less than 85 db(A) when under load.
- Non impacting - low vibration levels make these tools comfortable and safe to use.
- Square drive is quickly and easily replaceable.
- Bi-directional. The direction control knob is locked while the tool is running to prevent accidental damage to the gearbox.
- 'Soft Start' trigger control aids socket location and allows gradual and safe reaction location.
- For safety, gearbox can rotate independently from the handle so that reaction forces are not transmitted back to the operator.

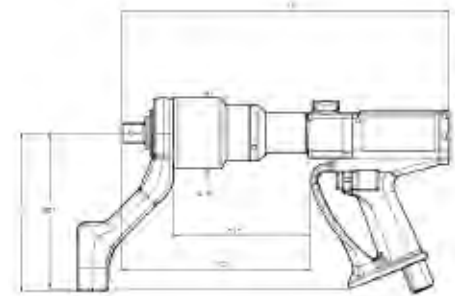

2700, 3500, 4500 and 6000 N.m Tools - Stall

| Model | Square Drive | Part No. | Range | | Free Speed † | Length 'A' | B | C | D | E | Tool Weight | Reaction Weight |
|----------------|--------------|-----------|-----------|----------|--------------|------------|-----|-----|-----|-----|-------------|-----------------|
| | in | | N.m | lbf.ft | | | | | | | | |
| PTM-92-2700-B | 1 | 18106.B08 | 540-2700 | 400-2000 | 57 | 387 | 178 | 243 | 205 | 92 | 8.5 | 1.35 |
| PTM-92-3500-B | 1 | 18107.B08 | 700-3500 | 520-2600 | 41 | 387 | 178 | 243 | 205 | 92 | 8.5 | 1.35 |
| PTM-119-4500-B | 1½ | 18108.B12 | 900-4500 | 660-3300 | 32 | 456 | 197 | 277 | 200 | 119 | 12.5 | 2.1 |
| PTM-119-6000-B | 1½ | 18109.B12 | 1200-6000 | 885-4500 | 25 | 456 | 197 | 277 | 200 | 119 | 12.5 | 2.1 |

† Speed at maximum air pressure.